



User's Manual



ATTENTION - Read before start-up

This appliance can be used by children aged 8 years and older and people with reduced physical, sensory or mental capabilities or lack of experience and knowledge if they have been given appropriate supervision or training in the use of the appliance in a safe way and understand the dangers involved. Children should not play with the appliance. Children without supervision should not do the cleaning and maintenance to be carried out by the user.

Recommended operating and rest times:

- Manual models: 3 minutes working, 15 minutes stop.
- Electronic models : 6 seconds working, 44 seconds stop.
- Cleaning instructions for parts in contact with food:

All cleaning must be done with the grinder unplug using On/OFF switch (11).

For the hopper's cleaning, you should remove the Hopper of coffee beans (2), wash it using a highly diluted solution of dishwasher liquid in water (by hand). Make sure the hopper is completely dry before re-attaching it.

For the blades' cleaning, remove the coffee beans Hopper (2), remove the platen by pressing the adjustment pawl (6). Cleaning using a dry brush. Replace all the parts.

For the dispenser's cleaning, empty the dispenser (8), remove the dispenser lid (7). Cleaning the dispenser with a dry brush. Replace the parts.

For the outer body of the coffee grinder cleaning, use a soft cloth dampened in water.

-How to properly use protections against moving parts:

There is a safety guard located in the lower portion of the coffee bean Hopper (2) to prevent contact with the grinding blades. This device lets the coffee beans drop but avoids the insertion of the fingers.

-How to properly fitting the protections against moving parts and



hazards that may exist if these parts are disassembled:

Before turning the coffee grinder, make sure the Hopper (2) is well-attached and fixed.

-Special precautions during installation:

Place the grinder on a flat and stable surface, in an appropriate distance from a ground mains outlet (approx. 110cm.), distanced from running water and heat sources. Minimum clearances: Width: 20cm. on both sides. Depth: 20cm in front of and behind the grinder. Height: 30cm. on the top of the grinder.

The electrical installation must be done by qualified personnel and following safety indications:

Make sure the electrical data on the coffee grinder's specification plate (see section 37 of this manual), connect the grinder to a grounded mains outlet meeting the country's regulation, protect the power source with a suitable magneto-thermal switch, having a suitable differential relay, make sure the mains wiring is suited to the device's power consumption, do not use cable extensions, adaptors or multiple-switch boards. If the power cord is damaged, it must be replaced.

Do not operate the coffee grinder while barefoot or with wet or damp hands or feet, avoid wetting the outer surface of the coffee grinder, avoid the penetration of solid objects in the interior of the grinder. Never turn on the grinder with any moving parts not correctly in place.

Put the Hopper cover (1) in place (on the top of the Hopper (2)) after filling it. Never run the coffee grinder without the Hopper (2) properly fixed. Never run the grinder without the dispenser lid (7) correctly in place. Take into account the maximum operation time detailed on the specification plate.

While filling the Hopper (2) make sure no objects accidentally fall into it. Always follow the instructions in this manual. Make sure the machine is not operated by anyone who has not read this manual.

ATTENTION - Read before start-up

- The appliance should not be cleaned under running water.
- If the power cord is damaged, the manufacturer must replace it, by its aftersales service or by similar qualified personnel.
- Any precautions that must be taken during the maintenance to be performed by the user:

Do not operate the coffee grinder while barefoot or with wet or damp hands or feet, avoid wetting the outer surface of the coffee grinder, avoid the penetration of solid objects in the interior of the grinder. Never turn on the grinder with any moving parts not correctly in place.

Put the Hopper cover (1) in place (on the top of the Hopper (2)) after filling it. Never run the coffee grinder without the Hopper (2) properly fixed. Never run the grinder without the dispenser lid (7) correctly in place. Take into account the maximum operation time detailed on the specification plate. While filling the Hopper (2) make sure no objects accidentally fall into it. Always follow the instructions in this manual.

Make sure the machine is not operated by anyone who has not read this manual.

Regular maintenance checks: if you observe any abnormal operation, turn off and unplug the coffee grinder immediately from the mains outlet and contact Cunill's Technical Service. Any possible repairs must be made by Cunill's Technical Service or by authorized dealer personnel. Do not try to modify the coffee grinder in any way. Use only Original Spare Parts, provided by the manufacturer in all repair work. All maintenance work should be done with the coffee grinder off and unplugged from the mains.

-Any safety instruction that is considered appropriate, apart from the previous ones required by the standard:

Cleaning precautions. Safety guidelines: before cleaning any part of the coffee grinder make sure you turn it off using the ON/OFF switch (11) and unplug it from the mains outlet. Never clean the grinder submerging in water. Do not use abrasive cleaners or chemical solvents.

Before using the coffee grinder, it is necessary to follow the instructions to fill with coffee beans, which is a maintenance operation to be carried out by the user:

Make sure the coffee bean Hopper (2) is correctly placed and attached. Close the trap (5) preventing the beans from entering to the blades. Lift the hopper lid by removing the fixing screws (1), fill the hopper (2) and close the lid. Except during the operation of filling with coffee beans and cleaning the hopper, it is essential that the lid is always in position to maintain the quality of the coffee and prevent the entry of any foreign body. Slide the trap (5) to its outer position letting the beans drop into the grinder.





00 Table of contents

Manufacturer's Identification	1-2
Identification of the Model	3
Welcome to the World of Cunill	4-5
Technical Specifications	6-7
Identification (Classic) of the Components	8
Machine Air Noise	9
Unpacking	10
Placement of Coffe Grinder	11
Electrical wiring	12
Before using the Coffee Grinder	13
Grinding Coffee Beans	14
Obtaining a Measure of Ground Coffee	15
Operating of the models MICHIGAN/HAWAI	16
Adjusting Coffee Grinding Level	17
Adjusting Ground Coffee Amount	18
Maximum Operating Time	19
Cleaning Precautions	20-24
Maintenance Precautions	25-28
Troubleshooting	29-30
Long-Term Storage	31
Usage Precautions	32
User-Adopted Safety Measures	33-35
Residual Risks	36
Specifications Plate	37
EC Conformity Declaration	38

When a number appears in the text in brackets (e.g. (9)), it refers to a part of the grinder which is detailed in section 08 (Identification of external components.

03 CUNILL Coffee Grinders

User's Manual. Use, Maintenance and Safety Instructions.

This User's Manual has been written to comply with EC regulations, (EN 2929-2, 5; and Appendix of the Machinery Directive - ECC Official Journal).

MOLCUNILL, manufacturer of CUNILL coffee grinders, reserves the right to modify the specifications detailed in this manual without prior notice, with the only intent to upgrade and enhance its products

02 Manufacturer's Identification

Manufacturer: MOLCUNILL, S.L
Brand Name: CUNILL
Country of Origin: ESPAÑA
Postal Address:
Carretera de Santa Coloma, s/n
Apartado de Correos nº 18.
17410 SILS - MALLORQUINES (GIRONA)
ESPAÑA

Tel. (National): 972.168282
Fax (Nacional): 972.853104
Tel. (Inter'l): +34.972.168282
Fax (Inter'l): +34.972.853104
www.cunill.com - email: cunill@cunill.com



MANUFACTURERS OF COFFEE GRINDERS
SINCE 1957



03 Identification of the Models

The usage and maintenance instructions detailed in this manual are applicable to all CUNILL brand-name coffee grinders which make up our present product range, with the following commercial names:

“CLASSIC”

(n°3)TRANQUILO,(n°3)TRANQUILO-2
(n°3)BRASIL,(n°3)TAURO,(n°5)SPACE,
(n°5)MARFIL(n°12)MICHIGAN.

“SILENCER”

(n°9)KENIA,(n°11)JAMAICA,(n°12)MOVIE
(n°12)LUXO,(n°12)LUXOMATIC,(n°12)
HAWAI

“ELECTRONICS”

(n°3)TRON-TRANQUILO,(n°9) TRON-
KENIA(n°11)TRON-JAMAICA,(n°12)
LUXOMATIC.

In their respective versions “w/handle” and “automatic”.

Our ESPECIAL BAR product, which is also part of our production, is simply a motorless ground coffee dispenser.

Therefore, its usage and maintenance specifications are the same as for our other manufactured products, expect for those referring to the motor.

Our products MICHIGAN, HAWAI depends on specific operating features that are different from the others. These are also described in this manual.

Our series of products called TOP-LINE, EXCLUSIVE, modify ONLY THE OUTER FINISH of the grinders. Usage, service and maintenance instructions ARE THE SAME FOR ALL MODELS.

04 Welcome to the World of CUNILL

We want to thank you for your trust in CUNILL coffee grinders, manufactured by MOLCUNILL.

The coffee grinder which you have just bought is manufactured following strict quality control standards, and has been designed applying ergonomical principles, so that you will have no problems whatsoever using it and so that it will provide comfortable and safe operation.

In this manual you will find all the information necessary for installing, using, maintaining and cleaning your coffee grinder. Follow all of these instructions carefully to ensure a long, trouble free life for your coffee grinder.

If any problem arises or you have doubts as to the contents of this manual, please do not hesitate to consult our Technical Service, which from this moment on is at your entire service.

Xavier Cunill
Product Manager



05 For you Safety and Good Operation

CUNILL coffee grinders are designed to provide safe, durable and reliable operation if used correctly. Therefore, it is VERY IMPORTANT to read this instruction manual carefully before using the coffee grinder for the first time. Follow each and every item in the order in which they appear, and pay even more attention to warnings regarding installation, use, maintenance and cleaning especially those sections marked with the symbol:

as they refer to operations which may be HAZARDOUS TO THE USER if not performed correctly.



If you fail to follow the instructions, incorrect use may cause bodily harm or material damage.

The manufacturer may not be held liable for any transformation, regulation, alteration and/or modification to coffee grinders not made by qualified personnel. These may lead to material damages or bodily harm.

Although the manual which you are reading right now is written in your country's language, we also have this manual in all official EC languages. If you wish to obtain one of these, or a translation into any other languages, please contact our Commercial Department, which will gladly provide it to you. (You will find our address and telephone number in this manual).

Store this manual in a safe place for future reference.

06 General Description

All of the machines presented in this manual are coffee grinders powered by electric motor and destined for commercial use.

07 Technical Specifications

(n°3) TRANQUILO-TRANQUILO-2 - TRON Models

H: 380mm L: 280mm W: 140mm Wei: 8Kg
Number of Motors: 1
Voltage: 230v -110v -Frequency: 50Hz-60Hz
Phases: 1(single) - Amperage:1,15A - 2,53A
Power: 0,10/270
Condenser: 10nf-450v - 40nf-400v
Speed: 1300-1650-Protection Degree: IP21.
Motor Equiped with Thermal Protector
Tempered Steel Grinding Wheels, 60mm.
Duration of Grinding Wheels:500kg Cof.B.
Hopper Capacity: 1/2Kg.
Dispenser Capacity: Direct fall to holder.
Disp. Adjustment: M/Placa electrónica.(Tra).
Disp. Adjustment: 5Gr - 12Gr.(Tranquilo-2)
-Manual.models:3minutes working, 15 minutes stop.
-Electronic.models:6 seconds working, 44 seconds stop.



07 Technical Specifications

(n°3) BRASIL - BRASIL-Inox Models

H: 450mm L: 355mm W: 210mm Wei: 8Kg
Number of motors: 1
Voltage: 230v-110v-Frequency: 50Hz-60Hz
Phases:1(single) - Amperage: 1,40A - 3,2A
Power:0,12/275
Condenser : 9nf-450v - 35nf-400v
Speed:1300-1650 Protection degree:IP21
Motor Equipped with Thermal Protector
Tempered Steel Grinding Wheels, 60mm
Duration of Grinding Wheels:500kg Cof.B.
Hopper Capacity:1Kg.
Dispenser Capacity:300 Gr.
Dispenser adjustment:5Gr - 12Gr.
-Manual.models:3minutes working, 15 minutes stop.

(n°3) TAURO Model

H: 560mm L: 290mm W: 180mm Wei: 8Kg
Number of motors: 1
Voltage: 230v-110v-Frequency: 50Hz-60Hz
Phases: 1(single) - Amperage:1,40A-3,2A
Power: 0,12/275
Condenser: 9nf-450v - 35nf-400v
Speed:1300-1650 Protection degree:IP21.
Motor Equipped with Thermal Protector
Tempered Steel Grinding Wheels, 60mm
Duration of Grinding Wheels:500kg Cof.B.
Hopper Capacity:1Kg.
Dispenser Capacity:600 Gr.
Dispenser adjustment: 5Gr - 12Gr.
-Manual.models:3minutes working, 15 minutes stop.l

(n°5) MARFIL - MARFIL-Inox Models

H: 610mm L: 355mm W: 210mm Wei: 9Kg
Number of motors:1
Voltage: 230v-110v-Frequency: 50Hz-60Hz
Phases: 1(single) - Amperage:1,80A - 3,7A
Power: 0,18/352
Condenser: 10nf-450v - 40nf-400v
Speed:1300-1650 Protection degree:IP21
Motor Equipped with Thermal Protector
Tempered Steel Grinding Wheels, 60mm
Duration of Grinding Wheels:500kg Cof.B.
Hopper Capacity: 2 Kg.
Dispenser Capacity: 600 Gr.
Dispenser adjustment:5Gr - 12Gr.
Optional: Automatic On/Off function.
-Manual.models:3minutes working, 15 minutes stop.

(n°5) SPACE Model

H: 610mm L: 310mm W: 180mmWei: 9Kg
Number of motors: 1
Voltage: 230v-110v-Frequency: 50Hz-60Hz
Phases: 1(single) - Amperage:1,80A - 3,7A
Power: 0,18/352
Condenser: 10nf-450v - 40nf-400v
Speed:1300-1650 Protection degree:IP21
Motor Equipped with Thermal Protector
Tempered Steel Grinding Wheels, 60mm
Duration of Grinding Wheels:500kg Cof.B.
Hopper Capacity: 2 Kg.
Dispenser Capacity: 600 Gr.
Dispenser adjustment: 5Gr - 12Gr.
Optional: Automatic On/Off function.
-Manual.models:3minutes working, 15 minutes stop.

07 Technical Specifications TRON "Electronic"

(n°9) KENIA - KENIA.TRON Models

H:210mm L:355mm W:210mm Wei: 11Kg
Number of motors: 1
Voltage: 230v-110v-Frequency: 50Hz-60Hz
Phases: 1(single)-Amperage: 1,75A - 3,9A
Power: 356W Condenser: 10nf-450v
-40nf-400nf
Speed:1300-1650 Protection degree: IP21.
Motor equipped with Thermal Protector
Tempered Steel Grinding Wheels 60mm
Duration of Grinding Wheels:500kg Cof. B.
Dispenser Capacity: 300 Gr.
Dispenser adjustment: 5Gr - 12Gr.
Automatic On/Off function
-Manual.models:3minutes working, 15 minutes stop.
-Electronic.models:6 seconds working, 44 seconds stop.

(n°11) JAMAICA - JAMAICA.TRON Models

H:210mm L:355mm W:210mm Wei: 12Kg
N° motores: 1
Voltaje: 230v-110v-Frecuencia: 50Hz-60Hz
Phases: 1(single)-Amperage: 1,55A - 3,9A
Power: 356W Condenser: 10nf-450v
-40nf-400nf
Speed:1300-1650 Protection degree: IP21.
Motor equipped with Thermal Protector
Tempered Steel Grinding Wheels: 60mm
Duration of Grinding Wheels:500kg Cof. B.
Dispenser Capacity: 600 Gr.
Dispenser adjustment: 5Gr - 12Gr.
Automatic On/Off function
-Manual.models:3minutes working, 15 minutes stop.
-Electronic.models:6 seconds working, 44 seconds stop.



07 Technical Specifications

(n°12) MICHIGAN Model

H:700mm L:355mm W:210mm Wei: 18Kg
Number of motors: 1
Voltage:230v-110v-Frequency:50Hz-60Hz
Phases: 1(single)-Amperage: 3,1A - 6,82A
Power: 0,50/680
Condenser: 20nf-450v -80nf-400v
Speed:1300-1650 - Protection degree: IP21.
Motor equipped with Thermal Protector
Tempered Steel Grinding Wheels, 65mm.
Duration of Grinding Wheels:500kg Cof.B.
Hopper Capacity: 2 Kg.
Dispenser Capacity: Bags
Dispenser adjustment: NO.
Special Bags filling.
-Manual.models:3minutes working, 15 minutes stop.



(n°12) MOVIE - "Silencer" Model

Al:660mm L:460mm W:265mm Wei: 18Kg
Number of motors: 1 (op) + 1motor-fan
Voltage: 230v-110v-Frequency: 50Hz-60Hz
Phases: 1(mono)-Amperage: 2,1A - 4,62A
Power:0,30/360
Condenser: 14nf-450v -55nf-400v
Speed:1300-1650. Protection degree: IP21
Maximum Continuous Service Time:30min.
Motor equipped with Thermal Protector
Tempered Steel Grinding Wheels, 65mm
Duration of Grinding Wheels:500kg
Cof.B.Capacidad tolva: 2 Kg.
Hopper Capacity: 600 Gr.
Dispenser adjustment: 5Gr - 12Gr.
On-Off: Automatic(Movie)
On-Off:Automatic every 8 coffees-Bi.motor
-Manual.models:3minutes working, 15 minutes stop.



07 Technical Specifications

(n°12) HAWAI - 2 - "Cooled" Model

H:600mm L:250mm W:210mm Wei: 20Kg
Number of motors: 1+ 2motor-fans
Voltage: 230v-110v-Frequency: 50Hz-60Hz
Phases: 1(mono)-Amperage: 5,75A -12,65A
Power: 0,75/980
Condenser: 90MF-230V - 400nf-125v
Speed: 1300-1650. Protection degree: IP21
Motor equipped with Thermal Protector
Tempered Steel Grinding Wheels, 65mm
Duration of Grinding Wheels:500kg Cof.B.
Hopper Capacity: 1/2 Kg.
Dispenser Capacity: BAGS
Dispenser adjustment: NO
Special Bags filling.
-Manual.models:3minutes working, 15 minu-
tes stop.

07 Technical Specifications LUXOMATIC "Electronic"

(n°12) LUXO - LUXOMATIC Models

H:560mm L:290mm W:180mm Wei: 18Kg
Number of motors: 1
Voltage:230v-110v-Frequency:50Hz-60Hz
Phases: 1(single)-Amperage: 2,1A - 4,7A
Power: 500W
Condenser: 16nf-450v - 55nf-400v
Speed: 1300-1650-Protection degree: IP21.
Motor equipped with Thermal Protector
Tempered Steel Grinding Wheels, 65mm.
Duration of Grinding Wheels:500kg Cof.B.
Hopper Capacity: 1Kg.
Dispenser Capacity: 600 Gr.
Dispenser adjustment: 5Gr - 12Gr.
Automatic On/Off function
-Manual.models:3minutes working, 15 minu-
tes stop.
-Electronic.models:6 seconds working, 44
seconds stop.



08 Components Identification (Classic)

1. Coffee bean hopper lid.
2. Coffee bean hopper
3. Fixing anchors
4. Grinder Adjustment platen
5. Trap of (open/close) bean hopper.
6. Adjustment pawl.
7. Ground coffee dispenser lid.
8. Ground coffee dispenser.
9. Ground coffee adjustment screw.
10. Ground coffee press..
11. On / Off switch.
12. Direct intake (seal-saver).
13. Coffee collection Tray.
14. Dosing lever

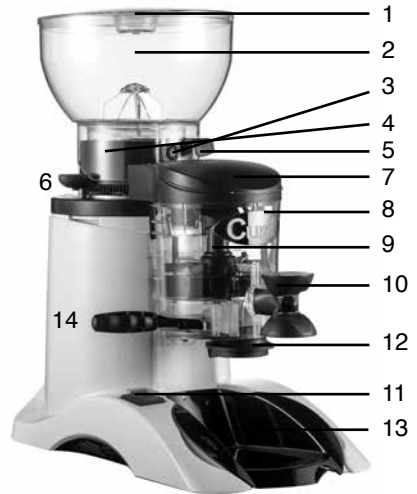

- 1 Hopper lid.
- 2 Hopper.
- 4 Split pin (opening/closing) of the hopper.
- 5 Adjustment pawl.
- 6 Selection-lever of adjustment.
- 7 Holding lever for the bags
- 8 Vibrating Stainless Steel plate.
- 9 On / Off switch.
- 10 Air exits.

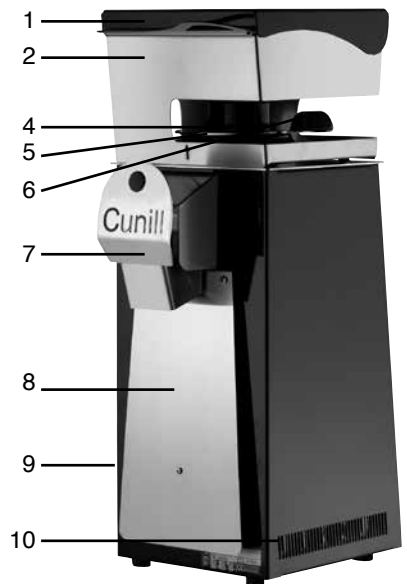

09 Machine Air Noise

The air noise value of CUNILL coffee grinders was estimated based on measuring noise levels in identical machines during the grinding process.

The continuous weighted "A" equivalent acoustic pressure level at the worksite for different coffee grinders is as follows:



MODEL - "Classic" dB-(A)

-(N°3) Tranquilo	70
-(N°3) Tranquilo-2	70
-(N°3) Brasil	70
-(N°3) Tauro	70
-(N°5) Space	70
-(N°5) Marfil	70
-(N°12)	70

MODEL-"Silencioso" dB-(A)

-(N°12) Hawaii	65
-(N°12) Movie	65
-(N°9) Kenia	63
-(N°11) Jamaica	63
-(N°12) Luxo	55

MODEL-"Electrónico" dB-(A)

-(N°3) TRON-Tranquilo	70
-(N°9) TRON-Kenia	63
-(N°11) TRON-Jamaica	63
-(N°12) Luxomatic	55

10 Unpacking

Before fully unpacking your coffee grinder, make sure that the model and colour indications marked on the box match the model that you have selected. If not, please contact your dealer.



Carefully remove the contents from the box and make sure the coffee grinder has not been damaged during transportation.

If you observe any damage, please inform your dealer without delay.

If you suspect that the coffee grinder or any of its parts are damaged or deteriorated, DO NOT USE THE DEVICE.

Contact CUNILL's Technical Service immediately or get in touch with MOLCUNILL authorized technical staff.

Before using the machine, remove all wrapping and make sure it is completely clean.

Take special pains to make sure that plastic bags and metal staples are kept out of the reach of children to prevent possible accidents.



Please, be environment - friendly. Do not dispose of the packing materials any which way. These can be recycled - both the plastic bag used to wrap the coffee grinder and the cardboard box itself are made with recyclable materials. Please check the related legislation in your country.

11 Placement of Coffee Grinder

The placement of the coffee grinder is a decisive factor, both for the perfect performance of the machine and for the user's health. Its placement in an inadequate site for use can result in adverse physiological effects, for instance, uncomfortable posture or unnecessary excess effort.

For this reason, please bear in mind the following precautions before deciding a site for the coffee grinder:

- a) Place it on a flat, stable surface, at a height which allows easy and safe operation.
- b) Place it at an appropriate distance from a grounded mains outlet which will allow you to effortlessly plug it in and unplug it (approx. 110 cm.).

Never pull the power cord to unplug the grinder; always grip the plug.

- c) Keep the following minimum clearances to ensure perfect operation of the coffee grinder, as well as for easy and safe use and cleaning:



WIDTH: There should be a minimum clearance of 20 cm. on both sides of the coffee grinder.

DEPTH: There should be a minimum clearance of 20 cm. in front of and behind the coffee grinder.

HEIGHT: There should be a minimum clearance of 30 cm. on top of the coffee grinder.

- d).-For your convenience, place the coffee grinder near the coffee espresso machine. This will avoid unnecessary trips back & forth.

- e) Do not place the coffee grinder near running water or places where foreign objects can penetrate the interior of the machine.

- f) Do not leave the coffee grinder near heat sources like radiators or air ducts, or where it can be subjected to direct sunlight, excess dust, rain, mechanical vibrations, or impacts.

- g) To avoid internal overheating, place the coffee grinder in a properly ventilated area.



12 Electrical Wiring

The electrical installation of your coffee grinder should be left to qualified personnel, always adhering to the following safety indications:

- a) Make sure the electrical data on the coffee grinder's Specifications Plate (see section 37 of this manual) match your mains power.
- b) The coffee grinder must be connected to a grounded mains outlet meeting your country's regulations.

Non-fulfilment of this requirement may constitute a serious hazard to your health. The manufacturer may not be held liable for any injuries or harm caused by a non-grounded mains power outlet.

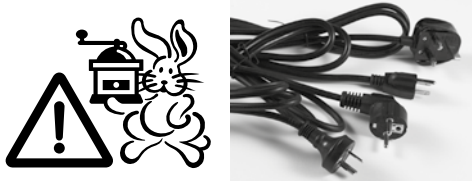

- c) The power source must be protected by means of a magneto-thermal switch suited to the power required by the coffee grinder, as indicated on the grinder's Specifications Plate (see section 37 of this manual).
- d) There should be a differential relay suited to the characteristics of the mains wiring.
- e) Make sure the mains wiring is suited to the device's power consumption.
- f) Do not use cable extensions, adaptors or multiple-switch boards or plugs to connect the coffee grinder to the mains outlet.
- g) If the power cord is damaged, it must be replaced by the manufacturer or its after-sales service or by qualified personnel in order to avoid a hazard.

13 Before Using the Coffee Grinder

Before using the coffee grinder for the first time, follow the instructions below to load coffee beans:

- a) Make sure the coffee bean hopper (2) is correctly placed and attached by the lock screw (3) to the grinder adjustment platen (4).
- b) Close the trap (5) preventing the beans from entering the grinder chamber.

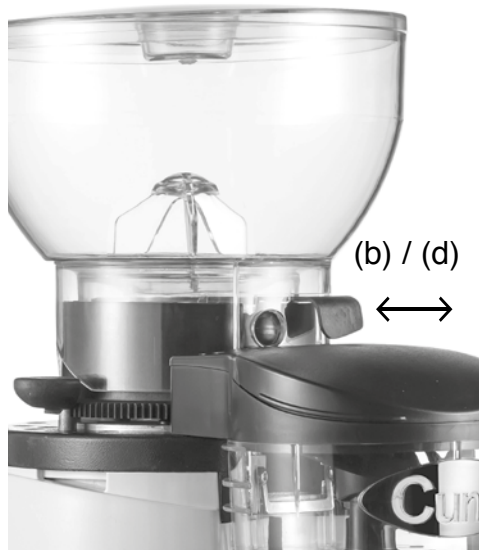

- c) Lift the hopper lid (1), fill the hopper with coffee beans (2) and close the lid.
- d) Slide the trap (5) to its outer position letting the beans drop into the grinder chamber.

The manufacturer may not be held liable for injuries or harm to persons and/or animals, or material damages resulting from the incorrect installation of the coffee grinder or failure to comply with any of the above indications.

14 Grinding coffee beans

Turn on the coffee grinder using the On/Off switch (11). The beans will pass through the grinder and the ground coffee will fill the ground coffee dispenser.

When the ground coffee dispenser (8) is full, stop the coffee grinder using the On/Off switch (11).

ONLY FOR MODELS WITH AUTOMATIC STOP:

After starting the coffee grinder using the On/Off switch (11), the machine stops automatically when the ground coffee dispenser (8) drops to a certain level, the coffee grinder starts up automatically, refills the dispenser (8) and shuts down automatically once the dispenser is full.



15 Grinding coffee beans

a) Place the coffee-holder of the coffee machine against the Seal-saver (12), located right below the dispenser's ground coffee outlet (8).



b) Pull the dispenser handle (14) towards you to obtain a single measure. Release the handle for it to return to its position.

c) Place the coffee-holder of the coffee machine under the ground coffee press (10) and press upwards to pack the ground coffee.



If you want to obtain the same dose of ground coffee every time, try to keep the dispenser (8) of ground coffee almost full. (Remember that this operation is automatic in models with the automatic stoppe forma automática).

16 Operating the(n°12) Michigan and the (n°12) Hawai-2 Models

The models Michigan and Hawai-2 are the only ones of our product range which does not dispense ground coffee in measures, but rather in “bulk”, therefore, its specific features only affect coffee dispensing.

a) In the model Hawai-2 is possible to regulate the type of ground coffee through the selection lever of adjustment (6) putting on the type of ground coffee desired, through the frontal upper arrow (coarse, medium, fine, espresso and Turkish).

b) Place the bag where you want to store the ground coffee under the holding-lever (7), the bag will be supported by the vibratory (8) plate through the one is possible a perfect settling of the ground coffee in the bag.

C) Turn on and off the grinder using the On/ Off switch (9).

This model has 1 main grinding “Silencer -63dB” motor and 2 fan motors to always get a regular grinding without overheating the ground coffee.

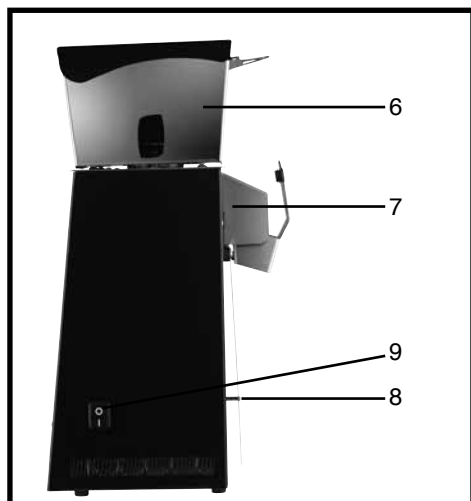

17 Adjusting Coffee Grinding Level

You can adjust the degree of grinding (finer/coarser ground coffee) by adjusting the grinder by means of the grinder adjustment platen (4) as follows:

To obtain a FINER ground coffee:

a) This operation is done with the grinder working.

b) Keep the adjustment trigger pressed to free the adjustment platen (4) and turn the platen TO THE RIGHT as indicated by the “F” arrow on the platen.



! ATTENTION:
If the adjustment platen (4) is completely removed from its emplacement, the grinding blades are fully exposed, with the consequent hazard if the coffee grinder is turned on.
● Never operate the coffee grinder without all its moving parts correctly in place.



18 Adjusting Ground Coffee Amount Dispensed by the Coffee Grinder

You can adjust the ground coffee dispenser (8) to obtain a SMALL MEASURE (minimum 5g.) up to a LARGE MEASURE (maximum 12 g.) as follows:

To obtain a SMALLER Measure:

- Stop the grinder using the ON/OFF switch (11).
- Remove the ground coffee dispenser lid (7).
- Turn the ground coffee screw (9) TO THE RIGHT.
- Replace the ground coffee dispenser lid (7).

To obtain a LARGER Measure:

- Stop the coffee grinder using the ON/OFF switch (11).
- Remove the ground coffee screw (9) TO THE LEFT.
- Replace the ground coffee dispenser lid (7).



19 Maximum Operating Time

The coffee grinder SHOULD NOT BE OPERATED CONTINUOUSLY FOR MORE THAN 30 MINUTES.

If you observe any abnormal operation, turn off the coffee grinder, unplug it immediately from the mains outlet, and contact CUNILL's Technical Service your dealer.



It is very important to regularly clean the coffee grinder's different parts. To avoid any incidents, you should clean the machine with the indicated frequency following these SAFETY GUIDELINES:

- Before cleaning any part of the coffee grinder (even the outer shell) make sure you turn it off using the on/off switch (11) and unplug the coffee grinder from the mains outlet.
- Never clean the coffee grinder using running water or submerging it in water.
- Never use abrasive cleaners or chemical solvents..

21 Cleaning the Hopper

Frequency: Every 25 days.

- Unplug the grinder using ON/OFF switch (11).
- Loosen the lock screws (3) which fasten the hopper to the adjustment platen (4) and remove the hopper (2).
- Clean the hopper using a highly diluted solution of dishwasher liquid in water. Always wash the hopper by hand, never place in the dishwasher.
- Make sure the hopper is completely dry before re-attaching it and locking the screws (3).



22 Cleaning the Grinding Blades

Frequency: Every 25 days.

Use a round brush with semi-rigid bristles. The brush should be long enough to reach all parts. Try to use a brush exclusively for cleaning the coffee grinder and store it in a clean, dry space.

a) Unplug the grinder using the ON/OFF switch (11).

b) Loosen the lockscrews (3) and remove the hopper (2).

c) Press the adjustment trigger (6) and keep it pressed to free the adjustment platen (4) and turn the platen **TOWARDS THE LEFT**, in the direction of the "G" arrow, until you remove the platen.



d) Clean the grinding teeth and all other elements in the housing using the brush, completely dry and without using any type of liquid.



e) Replace the adjustment platen (4) and turn it **TOWARDS THE RIGHT**, in the direction of the "F" arrow, until reaching the grinding position you want. (See section 17 for coffee grinding thickness adjustment).



23 Cleaning the Dispenser

Frequency: Every 25 days.

Use the same brush for cleaning the grinding blades.

a) Unplug the grinder using the ON/OFF switch (11).

b) Move the dispenser handle (14) back and forth as many times as needed to empty the dispenser (8).

c) Remove the dispenser lid (7).

d) Use the brush, completely dry and without using any type of liquid, to clean the inner surface of the dispenser (8). Move the dispenser handle (14) back and forth to clean thoroughly.

e) Replace the dispenser lid (7).



24 Cleaning the outer Body of the Coffe Grinder

If the outside of the coffee grinder becomes dirty, clean it with a soft cloth dampened in water. Remember to turn off the grinder using the On/Off switch (11) and unplug it before cleaning.

Cleaning of the interior of the coffee grinder should be performed **ONLY BY CUNILL TECHNICAL SERVICE STAFF.**

25 Maintenance Precautions

Regular maintenance checks are required to ensure optimum and reliable operation of the coffee grinder. It is **VERY IMPORTANT FOR YOUR SAFETY** to follow the guidelines below:

a) If you observe any abnormal operation, turn off the coffee grinder, unplug it immediately from the mains outlet, and contact CUNILL'S Technical Service.

NEVER ATTEMPT TO FIX THE COFFEE GRINDER YOURSELF.



b) Any possible repairs must be made by CUNILL's Technical Service or by authorized dealer personnel.

c) Do not try to modify the coffee grinder in any way.

d) Use only ORIGINAL SPARE PARTS provided by the manufacturer in all repairwork. (For greater convenience, there is even a "First-Aid Kit" for urgent repairs or quick replacement of parts subjected to greatest wear).

SPARE PARTS ORIGINAL CUNILL



e) All maintenance work should be done with the coffee grinder off and unplugged

26 Grinder Maintenance

It is important to check the condition of the grinding blades regularly. Wear of these pieces leads to lower ground coffee quality, more electrical consumption and hotter running of the electric motor.

To avoid these affects, the grinding blades should be replaced when the coffee grinder has been used to grind the amount of coffee beans (in Kilos) specified in the technical data for each model (section 8).

Replacement of the grinding blades should be performed by CUNILL'S Technical Service or by authorized dealer personnel.

27 Electrical Maintenance

Check the state of the power cord, plug and On/Off switch (11) regularly.

Should you observe any damage or wear, **DO NOT TURN ON THE COFFEE GRINDER.**



Keep it unplugged and immediately contact CUNILL's Technical Service. **DO NOT TRY TO REPAIR IT YOURSELF.**

28 General Maintenance

Make regular checks of the coffee grinder's different parts: coffee bean hopper (2), ground coffee dispenser (8), exterior of machine, etc.

Should you observe any damage or wear, **DO NOT TURN ON THE COFFEE GRINDER.**

Keep it unplugged and immediately contact CUNILL's Technical Service.

29 Troubleshooting: Coffee Grinder doesn't Start

Consult the manufacturer's Technical Service if the problem persists after making the following checks:

- a) Make sure the mains power is live (i.e., check for possible mains power failure)
- b) Make sure the electrical data on the specifications plate (see section 37 of this manual) match the mains power source.
- c) TURN OFF THE COFFEE GRINDER, unplug it and check the power cord, plug and On/Off switch (11).

30 Troubleshooting: Grinding blades don't turn

This problem is usually due to the presence of foreign objects in the coffee beans to be ground.

Consult the manufacturer's Technical service if the problem persist after making the following checks:

- a) Turn off the coffee grinder immediately using the on/Off switch (11) and unplug the machine from the mains outlet.
- b) If you notice that the coffee grinder has overheated due to clogage of the grinding blades, wait until it has cooled off completely.
- c) Follow the grinder cleaning instructions (section 22) to remove the foreign object.

31 Long-Term Storage

If the coffee grinder will not be used for a prolonged period of time, unplug it from the main outlet.

If you decide to put the coffee grinder entirely out of commission, CHECK WITH YOUR COUNTRY'S AUTHORITIES ABOUT POSSIBLE RECYCLING of the machine.

Please be environment-friendly - do not dispose of the coffee grinder any which way.



32 Usage Precautions

These coffee grinders are designed to be used only for grinding roasted coffee beans and dispensing the ground coffee obtained from the grinding process. For safety reasons, it should never be used for any other purposes.

Particularly, DON'T use the coffee grinder to grind and/or dispense foodstuffs (such as cereals, vegetables, fruit, nuts, sugar, etc.) or non-food products other than roasted coffee beans.

The manufacturer may not be held liable for injuries or other bodily harm to persons or animals or material damages in case of improper use of the coffee grinde

33 User-Adopted Safety Measures

Although CUNILL coffee grinders are equipped with all the safety devices and measures necessary for completely safe use, in order to prevent possible harm it is very important that the user follow the safety measures indicated below:



- a) Never handle or operate the coffee grinder while barefoot.
- b) Never handle or operate the coffee grinder with wet or damp hands or feet.
- c) Avoid wetting the outer surface of the coffee grinder. If it does get wet during operation, or even when not operating, unplug it immediately and dry it thoroughly.
- d) Avoid the penetration of solid objects in the interior of the coffee grinder. If any solid or liquid accidentally falls into the machine during operation or when stopped, unplug the coffee grinder immediately and have it checked by CUNILL's Technical Service.
- e) In general, never turn on the coffee grinder with any moving parts not correctly in place.
- f) Always put the hopper lid (1) in place (on top of the hopper (2)) after filling the hopper with coffee beans and before turning on the coffee grinder.
- g) Never run the coffee grinder without the hopper (2) correctly in place and attached by loc screws (3).
- h) Never run the coffee grinder without the dispenser lid (7) correctly in place.
- i) In general, coffee grinders should not be run continuously for longer than 30 minutes at a time (check the specifications plate attached to your coffee grinder).
- j) While filling the hopper (2), make sure no objects (necktie, scarf, hair, jewellery...) accidentally fall into the hopper or the adjustment platen (4).
- k) Always follow the instructions in this manual for all processes involving operation, cleaning and maintenance.
- m) Like with any other machine, make sure the machine is not operated by anyone who has not read this manual carefully and thoroughly, or who is not prepared to make appropriate use of the device, such as children.

34 Safety Device Preventing Contact with Grinding Blades

There is a safety guard located in the lower portion of the coffee bean hopper (2) to prevent contact with the grinding blades.

This device lets the coffee beans drop into the grinder housing, but prevents fingers from getting caught due to the small size of the hole.



35 Motor Thermal Protector

A thermal protector prevents overheating of the electric motor coils, cutting off power when the temperature rises above the maximum admissible level due to a malfunction like continued blockage of the motor

36 Residual Risks

IT IS VERY IMPORTANT FOR YOUR SAFETY

to make sure before turning the coffee grinder on that the hopper (2) is well-attached and fixed by the 2 fixing points (3). If not, when the coffee grinder is turned on, the grinding blades start to spin and can be easily touched with the fingers.



Therefore, UNDER NO CIRCUMSTANCES SHOULD THE COFFEE GRINDER BE TURNED ON WITHOUT THE HOPPER (2) IN PLACE AND SECURED TO THE ADJUSTMENT PLATEN (4) BY MEANS OF THE LOCKSCREWS (3).

37 Specifications Plate

You will find the specifications plate stuck on the coffee grinder which we enclose to it THIS USER'S MANUAL.
The content is:

	
MOLCUNILL . S.L	
Telf. (972) 168282 - Fax. (972) 853104	
Crta. Sta. Coloma, s/n -Apto -18 -17410 - Mallorquines (Girona) - ESPAÑA	
<p>Model:..... <input type="text"/></p> <p>230V / 50Hz / /W 220V / 60Hz / /W 110V / 60Hz / /W</p> <p>.....A /Rpm</p> <p>Manual models : 3 minutes working Manual models : 15 minutes stop</p> <p>IP - 21</p>	<p>Model:..... <input type="text"/></p> <p>230V / 50Hz / /W 220V / 60Hz / /W 110V / 60Hz / /W</p> <p>.....A /Rpm</p> <p>Electronic models : 6 seconds working Electronic models : 44 seconds stop</p> <p>IP - 21</p>
2006 / 42 / CEE	
Fecha fabricación: 2018 <input type="checkbox"/> 2019 <input type="checkbox"/> 2020 <input type="checkbox"/> 2021 <input type="checkbox"/> 2022 <input type="checkbox"/>	

38 EC Conformity Declaration



WE HEREBY DECLARE, under our own responsibility and save higher authorized criteria, that the machines detailed below meet the basic safety and health requirements of the EC directive in terms of design, construction and the version commissioned by ourselves.

Machine Denomination: Coffee Grinder.

Classic Machine Type: Models (n°3) TRANQUILO (instant), (n°3) TRANQUILO-2 (w/handle), (n°3) BRASIL (w/handle), (n°3) TAURO (w/handle), (n°5) SPACE (w/handle-automatic), (n°5) MARFIL (w/handle-automatic), (n°12) MICHIGAN (bags).

Silencer Machine Type: Models (n°9) KENIA(w/handle-automatic), (N°11) JAMAICA (w/handle-automatic), (N°12) MOVIE (w/handle-automatic), (N°12) HAWAI (bags).

Electronic Machine Type: (N°3)TRON.TRANQUILO (instant),(N°9) TRON.KENIA (instant), (n°11) TRON.JAMAICA (instant), (n°12) LUXOMATIC (instant).

Manufacturing Serial Number: Indicated on the specifications plate (see section 37) stucked on the machine accompanying this USER's MANUAL.

Directives Applied: EC Machines directive 2006/42/CEE.

-IEC 60335-2-64:2002 (Third Edition) +A1 in conjunction with IEC 60335-1:2010 (Fifth Edition) + A1:2013

-EN 60335 1: 2012 + AC: 2014 + A11:2014

-EN 60335-2-64:2004 (Also evaluates EN60335-2-64: 2000 + EN 60335-2-64:2000 CORR: 2002+ EN 60335-2-64/A1: 2002)

-EN 62233:2008

-SASO IEC 60335-2-64

-KC 60335-1

Specific application Standardised Regulations: EN 292-1 & 2, Machine Safety.
EN 60.204-1, Machine Electrical Equipment.

Manufacturer's Signature:

Por MOLCUNILLS.L
Joel Cunill
General Manager





TRANQUILO



TRANQUILO TRON



TRANQUILO II



BRASIL



LUXO



LUXOMATIC



KENIA TRON



MARFIL



JAMAICA TRON



MOVIE